

KVN

DN 65-200

Flange design, pressure-balanced piston

GENERAL FEATURES

- » Piston valve with bore
- » Pressure-balanced design
- » Sealing via three elastic KX-GT valve rings
- » Excellent control characteristics
- » Fire Safe
- » Special regulating design available (KVRLN)

CONNECTIONS

- Flange in accordance with EN 1092-2 (Mat. code III)
- Flange in accordance with EN 1092-1 (Mat. code VIII)

DIMENSIONS

EN 558-1, GR. 1

ACCEPTANCE TESTING

- » Seat leak tightness: EN 12266-1 P12, leakage rate A
- » Tightness to atmosphere: EN 12266-1 P11
- » Strength: EN 12266-1 P10

TEMPERATURE

-10 °C to +400 °C (see P-T diagram)

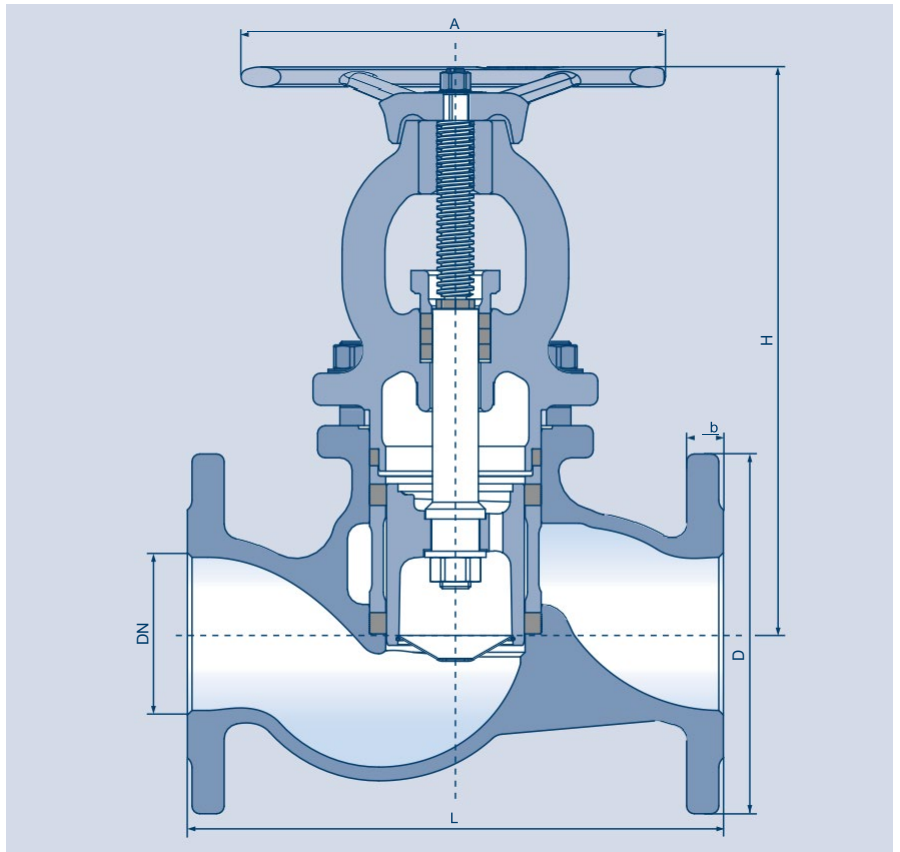

KVN FLANGE DESIGN DN 65-200

MATERIAL

- » Grey cast iron EN-GJL-250 / 5.1301 (Material code III)*
- » Cast steel 1.0619 (Material code VIII)

* refers to body, upper parts consist of VIII

DN	Dimensions			PN 16			PN 40			PN		Weight in kg	
	L	H	A	D	b	Hub	D	b	Hub	III/VIII	VIII	PN 16	PN 40
65	290	306	250	185	20	47	185	22	47	16	40	25	26
80	310	324	250	200	22	57	200	24	57	16	40	32	33
100	350	370	280	220	24	63	235	24	63	16	40	45.5	46
125	400	441	400	250	26	83	270	26	83	16	40	68	72.5
150	480	467	400	285	26	93	300	28	93	16	40	95	104.5
200	600	560	400	340	30	116	375	34	116	16	40	162	178